

Micro Electronics 120 Lab #3

Resource Materials:

Digital Electronics Textbook Chapter 3

Questions: (Answer on separate sheet)

1. Draw the logic symbol, Boolean expression, and Truth Table for a NOT gate.
2. What is a Buffer?
3. Draw a Schematic Diagram of a 7404 TTL IC, showing the arrangement of the individual gates.
4. What does the line over the A mean, in the Boolean Expression for the Inverter?

Procedure:

MATERIALS

Qty.		Qty.	
1	7404 hex inverter IC	1	logic switch
6	LED indicator-light assemblies	1	5- V dc regulated power supply

SYSTEM DIAGRAMS

See Figures 3-7 and 3-8.

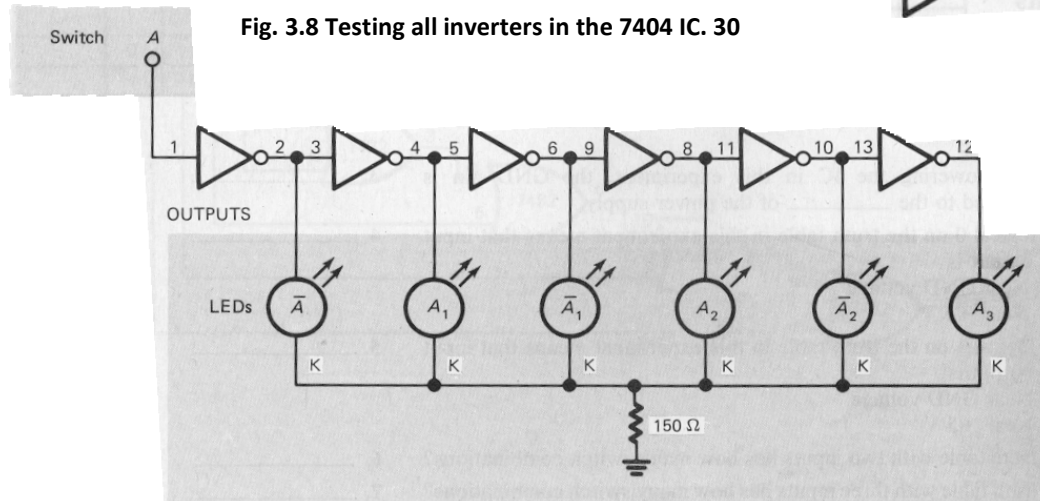
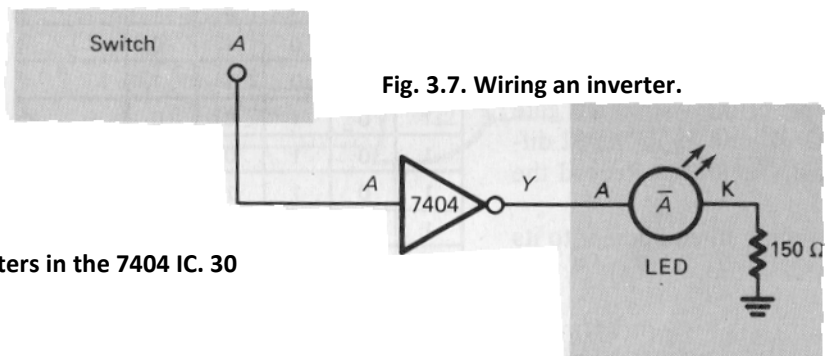

Instructions:

1. Insert a 7404 IC into the mounting board.
2. Power OFF. Connect power to the 7404 IC: the red wire for + 5 V (V_{cc}) and the black wire for GND.
3. Refer to Fig. 3-7. Wire the inverter (input switch, 7404 IC, and LED indicator-light assemblies). Refer to pin in diagrams in Appendix A.

4. On a separate piece of paper, make copies of **Tables 3-6** and **3-7**. Power ON. Move the input switch to the positions shown in the Input column, Table 3-6. Observe and record the results in the Output column, Table 3-6.
5. Power OFF. Wire the circuit diagramed in **Fig. 3-8** to test all six inverters in the 7404 IC package. Pin numbers are shown in **Fig. 3-8**.
6. Power ON. Operate the input switch and observe the results on the six output LED indicators. Record the results in **Table 3-7**.
7. Power OFF. Look over the results in **Table 3-7** and decide if the six inverters in the 7404 IC are working properly. Contact your instructor if you find a faulty inverter .
8. Take down the circuit and return all equipment to its proper place.

Table 3-6 Truth Table- Inverter

INPUT	OUTPUT
A	\bar{A}
0	
1	

Table 3-7 Test Results-7404 IC .

INPUT	OUTPUTS					
	\bar{A}	A_1	\bar{A}_1	A_2	\bar{A}_2	A_3
0						
1						

Lab Questions:

Complete questions 1 to 6 on a separate sheet of paper.

1. The power connection (V cc) on the 7404 IC is connected to whaton the power supply?
2. An input of near + 5 V on a 7404 inverter will produce an output of _____ volts from the inverter.
3. The output of an inverter will be a logical _____, with a logical 1 input.
4. If we invert a signal twice, what output do we get from the second inverter?
5. The Boolean expression \bar{A} means what?
6. Draw two logic symbols for an inverter.